

## ▼ 1. Stock

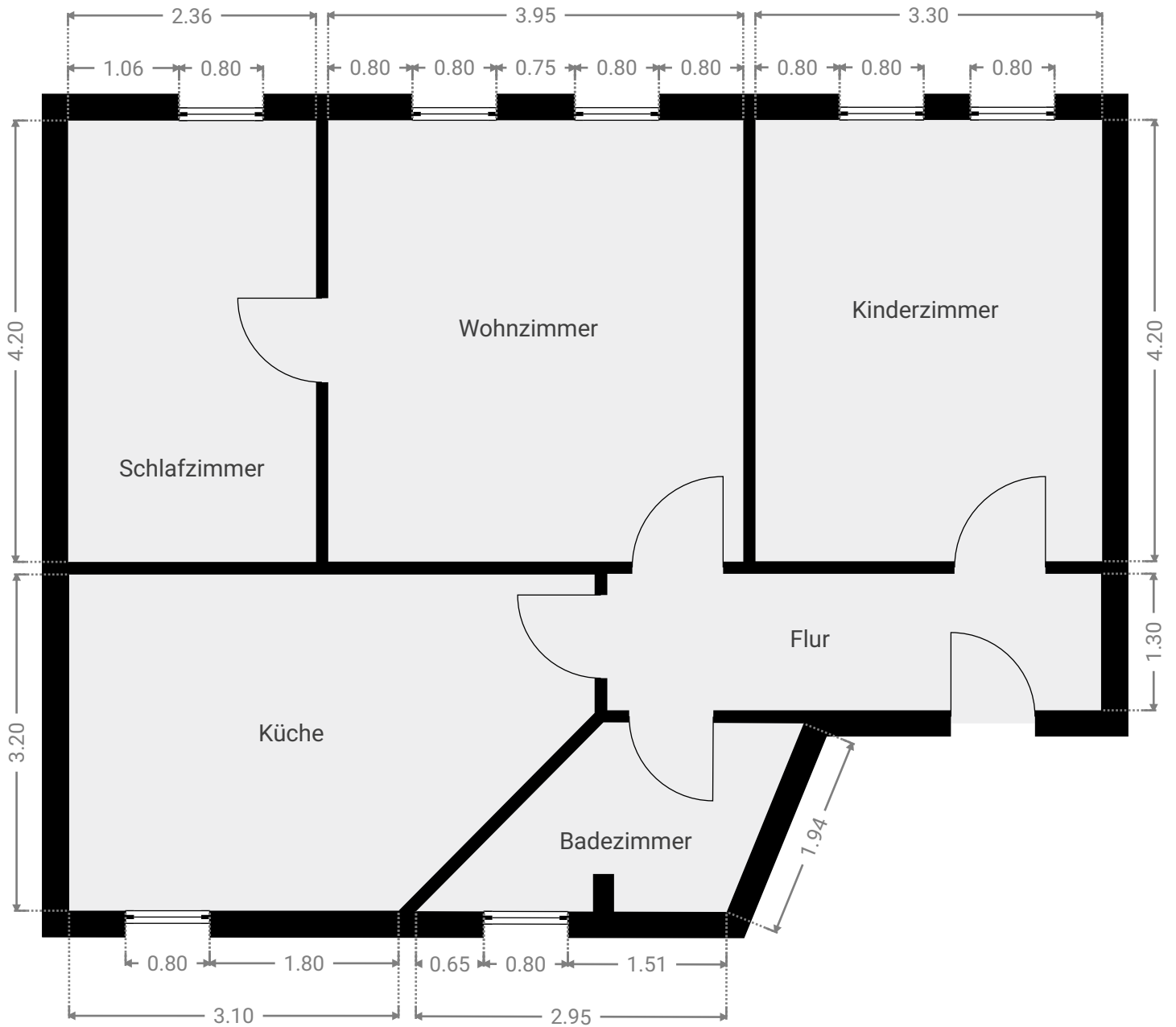

## ▼ Badezimmer 1. Stock

BREITE: 3.68 m · LÄNGE: 1.81 m  
BEREICH: 4.37 m<sup>2</sup> · UMFANG: 9.33 m

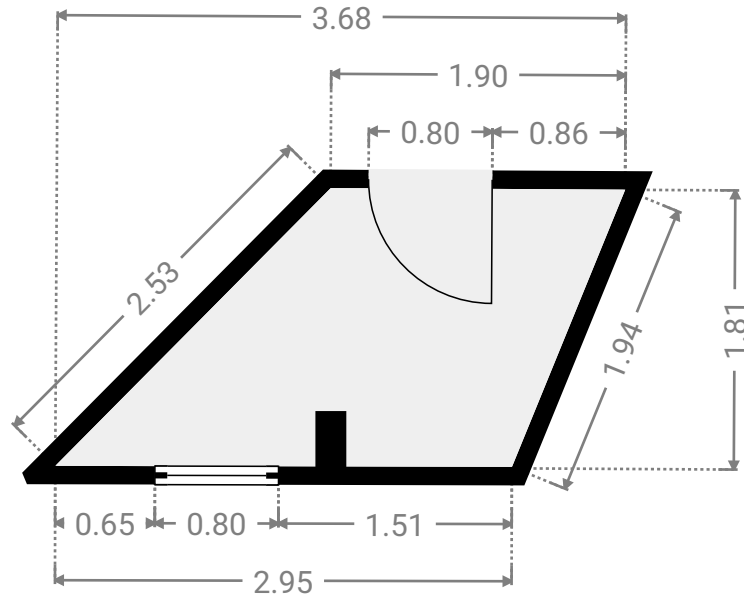
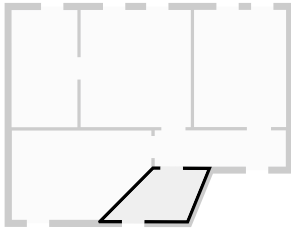

## ▼ Flur 1. Stock

BREITE: 4.70 m · LÄNGE: 1.30 m  
BEREICH: 6.11 m<sup>2</sup> · UMFANG: 12.00 m

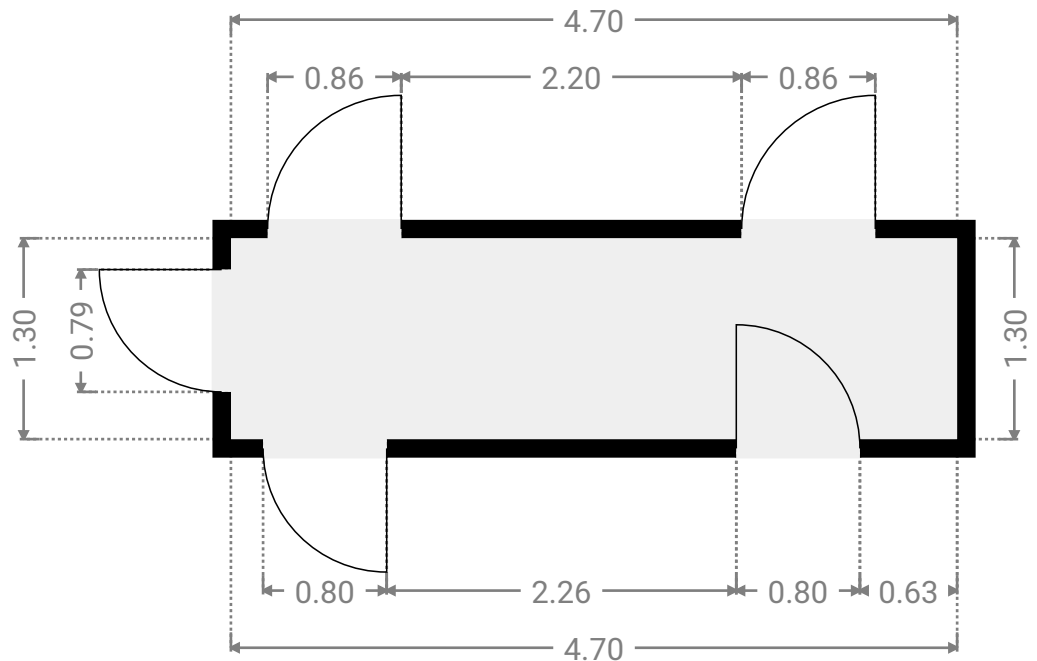
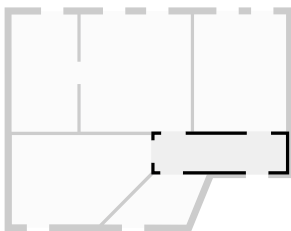

## ▼ Kinderzimmer 1. Stock

BREITE: 3.30 m • LÄNGE: 4.20 m  
BEREICH: 13.86 m<sup>2</sup> • UMFANG: 15.00 m

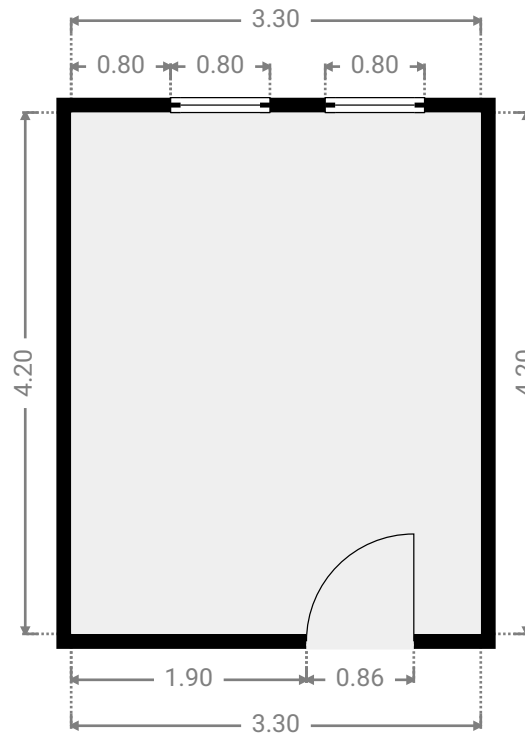
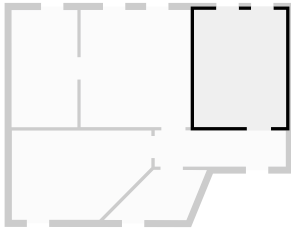

## ▼ Küche 1. Stock

BREITE: 5.00 m • LÄNGE: 3.20 m  
BEREICH: 14.25 m<sup>2</sup> • UMFANG: 15.30 m

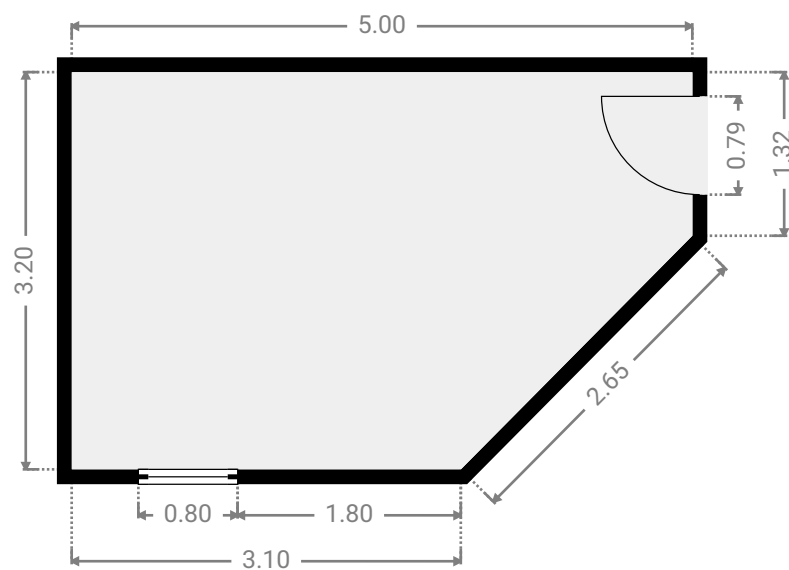
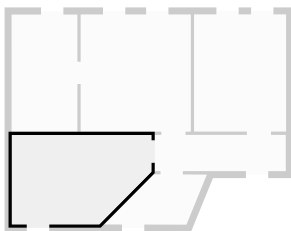

## ▼ Schlafzimmer 1. Stock

BREITE: 2.36 m • LÄNGE: 4.20 m  
BEREICH: 9.91 m<sup>2</sup> • UMFANG: 13.12 m

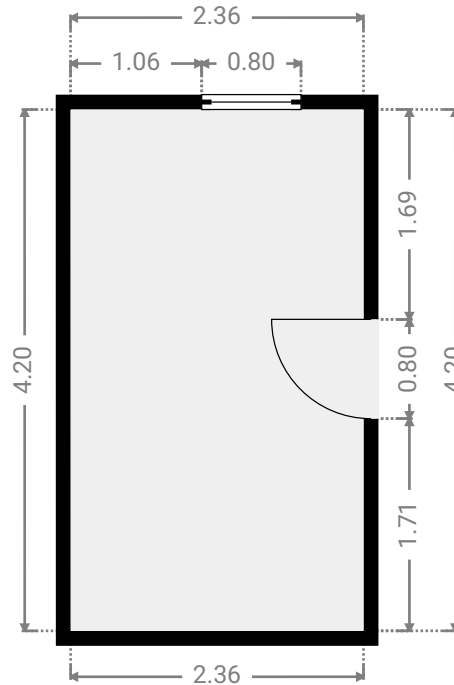
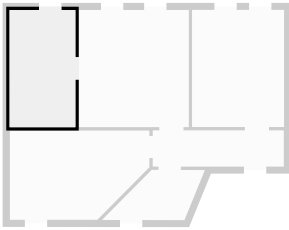

## ▼ Wohnzimmer 1. Stock

BREITE: 3.95 m • LÄNGE: 4.20 m  
BEREICH: 16.59 m<sup>2</sup> • UMFANG: 16.30 m

